

RESOLUTION NO. 6371-2021

A RESOLUTION OF THE CITY COUNCIL OF THE CITY OF SEBASTOPOL  
ADOPTING THE STREET STANDARD DETAILS AND SPECIFICATIONS ("STREET STANDARDS")

WHEREAS, the City of Sebastopol has previously adopted the City of Sebastopol Standard Details and Specifications, more commonly referred to as "Standards," including the Street Standards, by Resolution No. 4978 on September 1, 1998; and

WHEREAS, said Street Standards should periodically be updated to comply with current engineering best practices, and state and federal regulations; and

WHEREAS, the City Engineer has reviewed the updated Street Standards and recommends adoption; and

WHEREAS, minor discrepancies may be found from to time.

NOW, THEREFORE, BE IT RESOLVED that the City Council adopts the Street Standard Details and Specifications ("Street Standards") dated June 2021 attached hereto as Exhibit "A," and

BE IT FURTHER RESOLVED, that the City Engineer is authorized to make minor changes to the Street Standards to correct errors, conflicts, and discrepancies.

The above and foregoing Resolution was duly passed, approved, and adopted at a meeting by the City Council on the 7th day of September 2021, by the following vote.

VOTE:

Ayes: Councilmembers Hinton, Rich, Slayter, Vice Mayor Gurney and Mayor Glass  
Noes: None  
Absent: None  
Abstain: None

APPROVED:  \_\_\_\_\_  
Mayor Ura Glass

ATTEST:  \_\_\_\_\_  
Mary Gourley, Assistant City Manager/City Clerk, MMC

APPROVED AS TO FORM:  \_\_\_\_\_  
Larry McLaughlin, City Attorney

**SECTION 5**

**STREET STANDARDS**

- R-1.1 Street Layout
- R-1.2 Street Section
- R-1.3 Cul-De-Sac
  
- R-2.1 Curb, Gutter and Sidewalk
- R-2.2 Cross Gutter
  
- R-3.1 Pedestrian Ramp Type A
- R-3.2 Pedestrian Ramp Type B and C
  
- R-4.1 Commercial Driveway and Alley Approach
- R-4.2 Driveway
  
- R-5.1 City Monument
- R-5.2 Street Name Sign and Sidewalk Warp
- R-5.3 Standard Barricade
- R-5.4 Pavement Markings: Center Lines, Two-Way Left Turn Lanes, and Median Islands
  
- R-6.1 Street Light
- R-6.2 Street Light Pole Foundation

STREET TYPE	A CURB TO CURB WIDTH	B RIGHT-OF-WAY WIDTH	C CURB RETURN RADIUS
ARTERIAL	40'	64'	30', 35' AT STATE HWY
COLLECTOR	36'	60'	25'
LOCAL	32'	44'	20'
CUL DE SAC	36'	60'	25'

NOTES:

1. ADDITIONAL SIDEWALK EASEMENTS REQUIRED.
2. ADDITIONAL PUBLIC UTILITY EASEMENTS MAY BE REQUIRED ON BOTH SIDES OF RIGHT-OF-WAY.

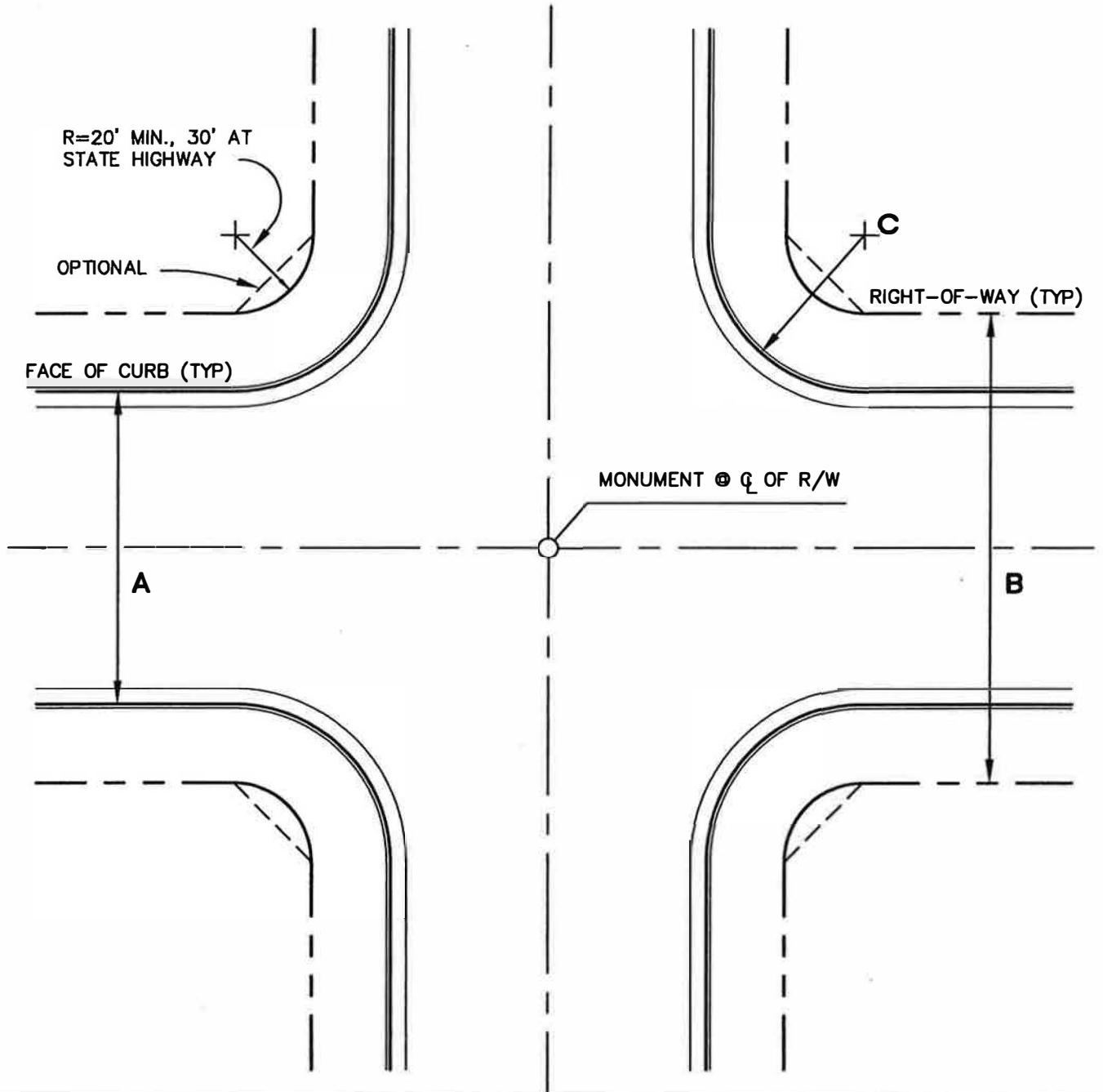

STREET LAYOUT

STD. NO.  
**R-11**

SCALE: NONE

DRAWN: LMM

APPROVED

JG, CITY ENG.

DATE: JUNE 2021

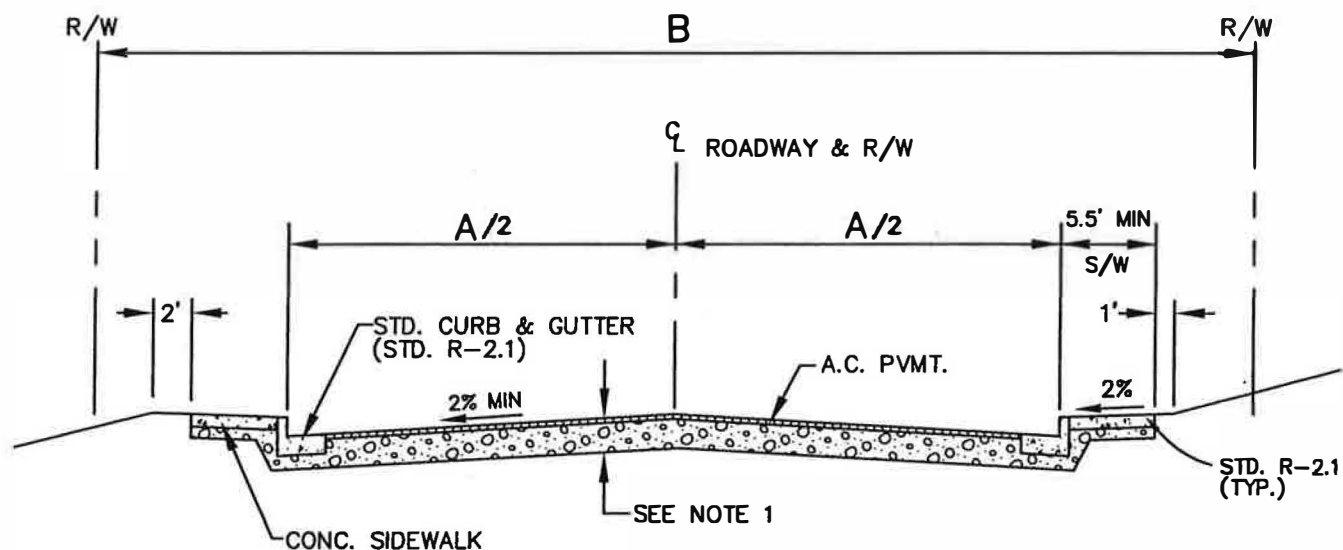

**NOTES:**

1. STRUCTURAL SECTION OF ROADWAY SHALL BE DETERMINED BY SOILS REPORT AND SHOWN ON PLANS, SHOW "R" VALUE & T.I.
2. CUT SLOPES SHALL BE A MAXIMUM OF 2:1, UNLESS SOILS REPORT DETERMINES OTHERWISE.
3. FILL SLOPES SHALL BE A MAXIMUM OF 2:1
4. CONSTRUCTION OUTSIDE R/W LINE SHALL REQUIRE SLOPE EASEMENTS.
5. A 5'-10' P.U.E. AND SIDEWALK EASEMENTS REQUIRED ADJACENT TO THE RIGHTS-OF-WAY.



**STREET SECTION**

**STD. NO.  
R-12**

SCALE: NONE

DRAWN: LMM

APPROVED:

JG, CITY ENG.

DATE: JUNE 2021

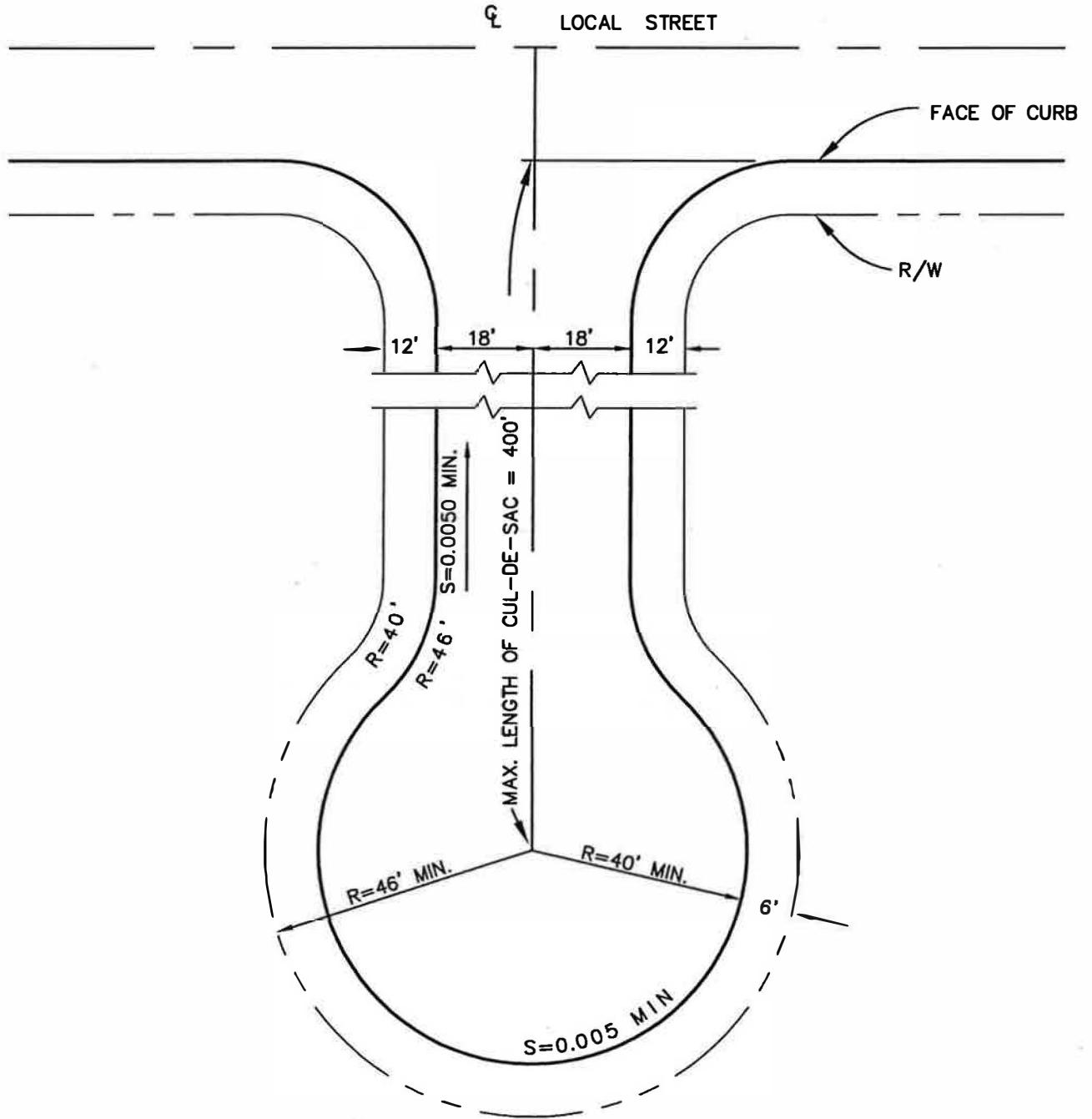

CROSS SLOPE IN BULB AREA  
SHALL BE MIN 2%.

**NOTES:**

1. ADDITIONAL SIDEWALK EASEMENT REQUIRED IN BULB.
2. ADDITIONAL PUBLIC UTILITY EASEMENTS MAY BE REQUIRED ON BOTH SIDES OF RIGHT-OF-WAY.



**CUL-DE-SAC**

**STD. NO.  
R-13**

SCALE: NONE | DRAWN: LMM | APPROVED: JG, CITY ENG. | DATE: JUNE 2021

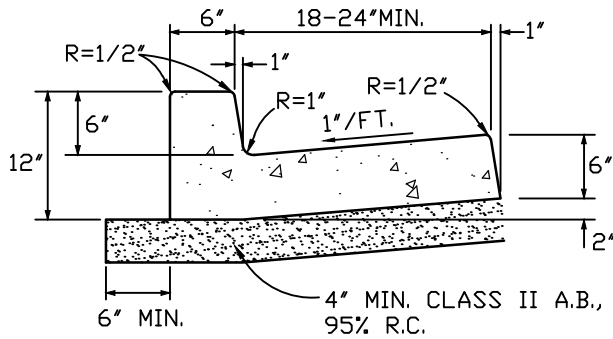

**STANDARD  
CURB AND GUTTER**  
NOT TO SCALE

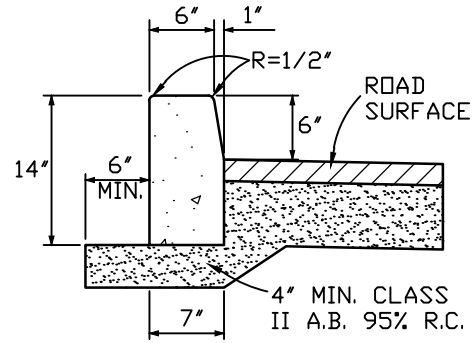

**STANDARD  
VERTICAL CURB**  
NOT TO SCALE

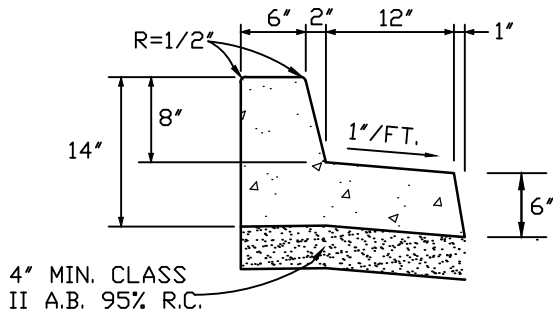

**TYPE A MEDIAN CURB**  
NOT TO SCALE

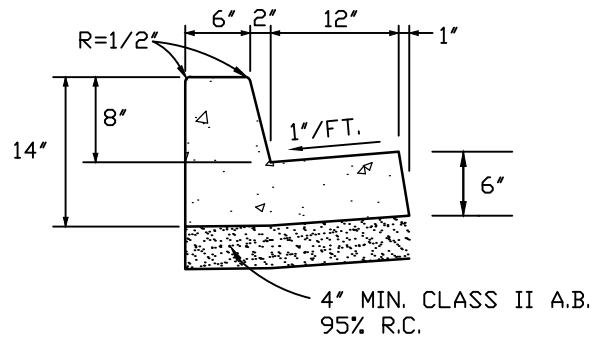

**TYPE B MEDIAN CURB**  
NOT TO SCALE

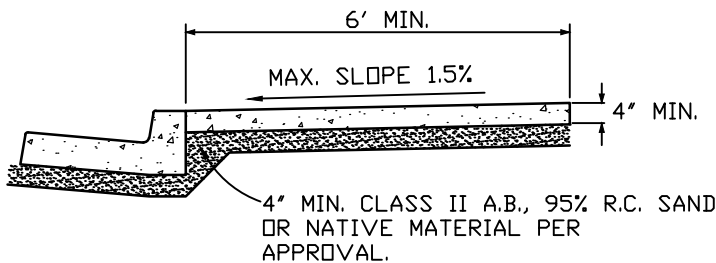

**STANDARD SIDEWALK**  
NOT TO SCALE

**NOTES:**

1. CONCRETE SHALL BE CLASS A AND SHALL CONTAIN NOT LESS THAN 6 SACKS OF CEMENT PER CUBIC YARD.
2. EXPANSION JOINTS, 1/4 INCH WIDE, SHALL BE INSTALLED AT EACH SIDE OF STRUCTURES, AT ENDS OF CURB RETURNS AND AT THE TOP OF DRIVEWAY TAPERS.
3. EXPANSION JOINTS SHALL BE INSTALLED AT 60FT INTERVALS, WITH WEAKENED PLANE JOINTS EVERY 15 FEET.
4. EXPANSION JOINTS SHALL BE PLACED IN CURB, GUTTER AND SIDEWALK AT ALL CURB RETURNS.
5. SIDEWALKS SHALL BE SCORED INTO 5 FOOT SQUARES UNLESS OTHERWISE SPECIFIED BY ENGINEER.
6. IF EXTRUSION MACHINE IS USED, EXPANSION JOINTS SHALL BE DEEP SCORED 1/3 THE THICKNESS.
7. WEIGHT OF CURB AND/OR SIDEWALK AND CLASS 2 AGGREGATE BASE SHALL EXCEED THE EXPANSION PRESSURE OF THE BASEMENT SOIL 'R' VALUE
8. DESIGN SHALL CONFORM TO THESE REQUIREMENTS EXCEPT AS OTHERWISE APPROVED BY THE CITY ENGINEER.
9. WHERE APPLICABLE, NEATLY CUT AND REMOVE PAVEMENT. REPLACE WITH NEW A.C. AFTER CURB AND GUTTER IMPROVEMENTS ARE COMPLETE.
10. NEW CONCRETE POURED ADJACENT TO EXISTING CONCRETE SHALL CONTAIN AT LEAST ONE POUND OF LAMPBLACK PER CUBIC YARD.



**CURB, GUTTER AND SIDEWALK**

STD. NO.  
**R-2.1**

SCALE: NONE | DRAWN: LMM | APPROVED: JG, CITY ENGINEER

DATE: JUNE 2021

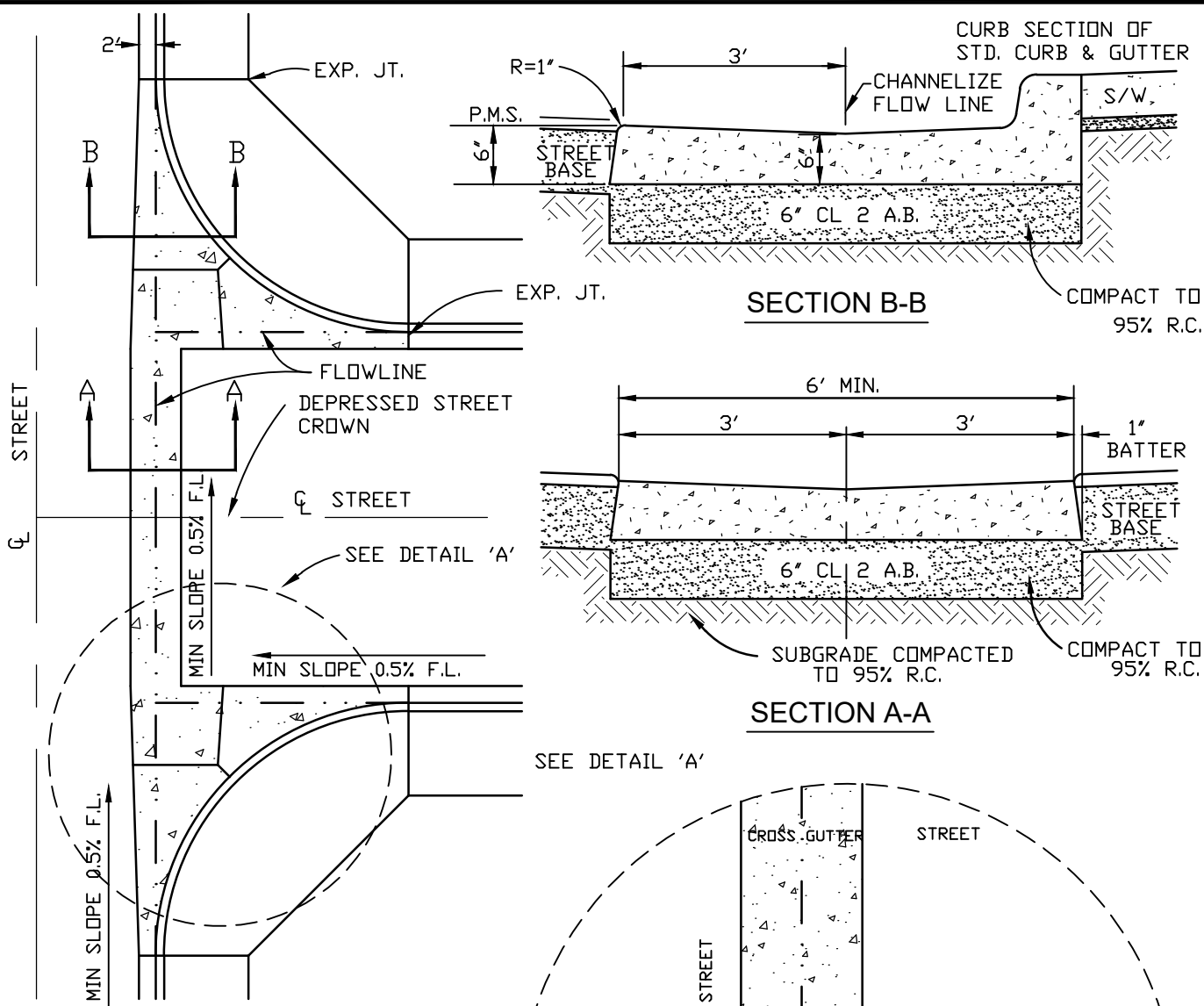

**TYP. CROSS-GUTTER PLAN**

**NOTES:**

1. ALL CONCRETE SHALL BE CLASS "A" (6 SACK/ CU. YARD)
2. NEW CONCRETE POURED ADJACENT TO EXISTING CONCRETE SHALL CONTAIN AT LEAST ONE POUND OF LAMPBLACK PER CUBIC YARD.

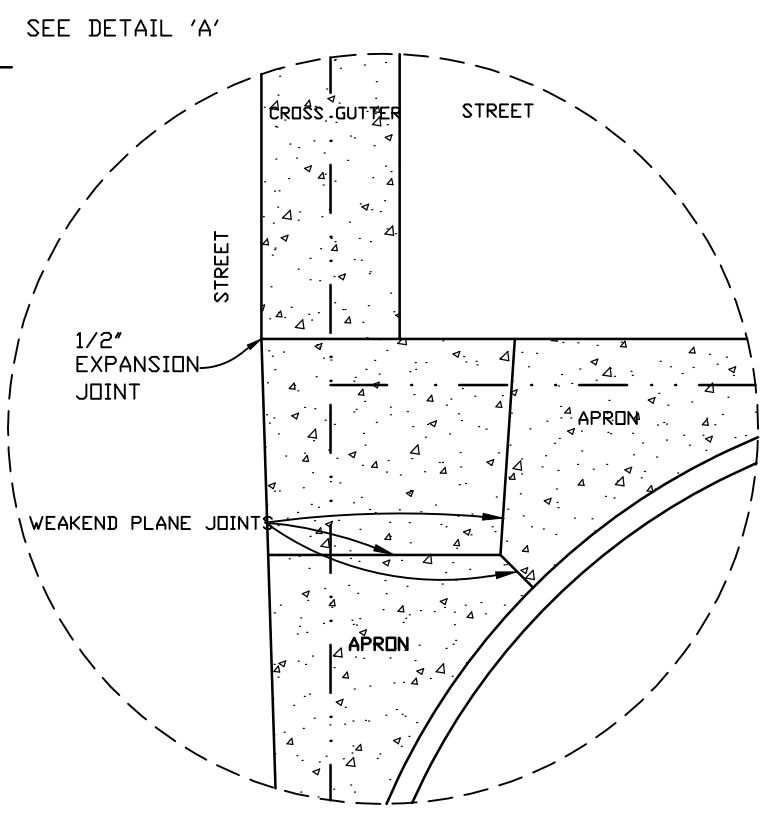

**DETAIL "A"**  
TYPICAL BOTH SIDES



**CROSS GUTTER**

STD. NO.  
**R-2.2**

SCALE: NONE | DRAWN: LMM | APPROVED: JG, CITY ENGINEER

DATE: JUNE 2021

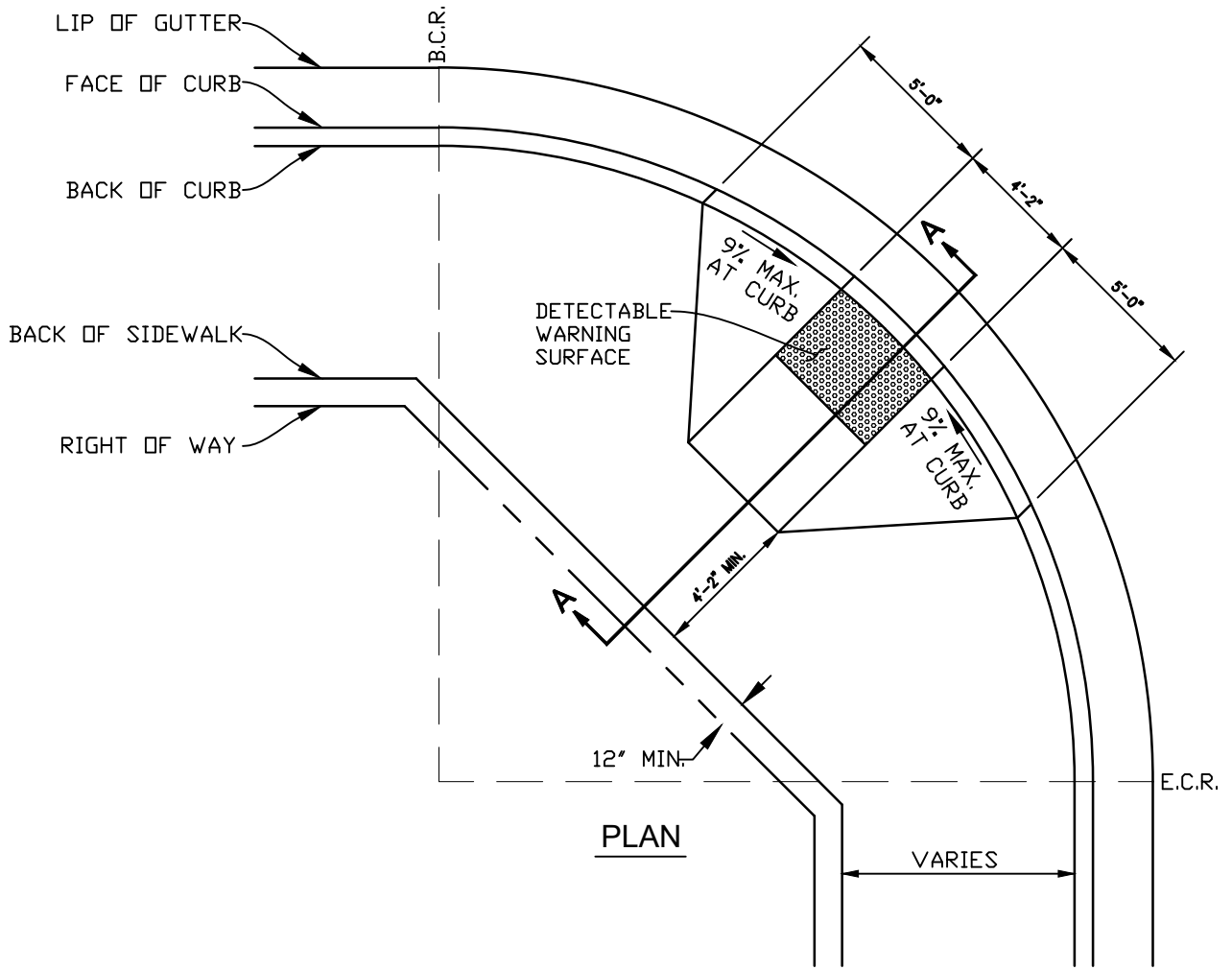

PLAN

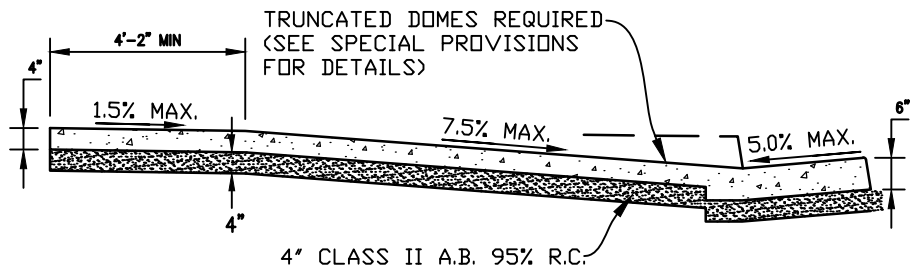

SECTION A-A



**PEDESTRIAN RAMP TYPE A**

STD. NO.  
**R-3.1**

SCALE: NONE | DRAWN: LMM | APPROVED: JG, CITY ENGINEER

DATE: JUNE 2021



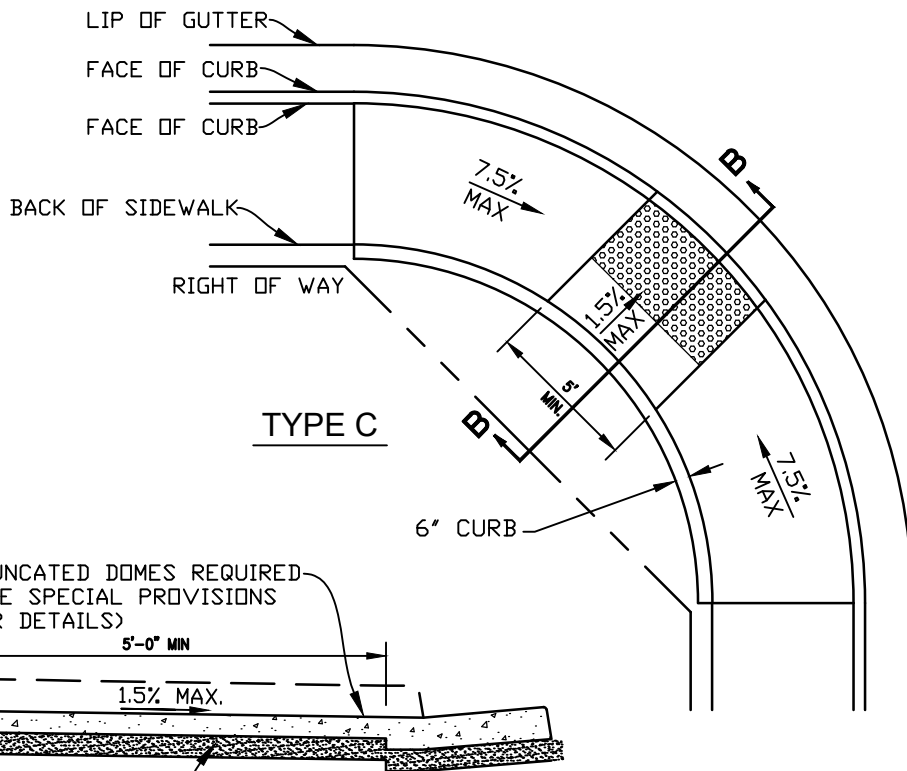
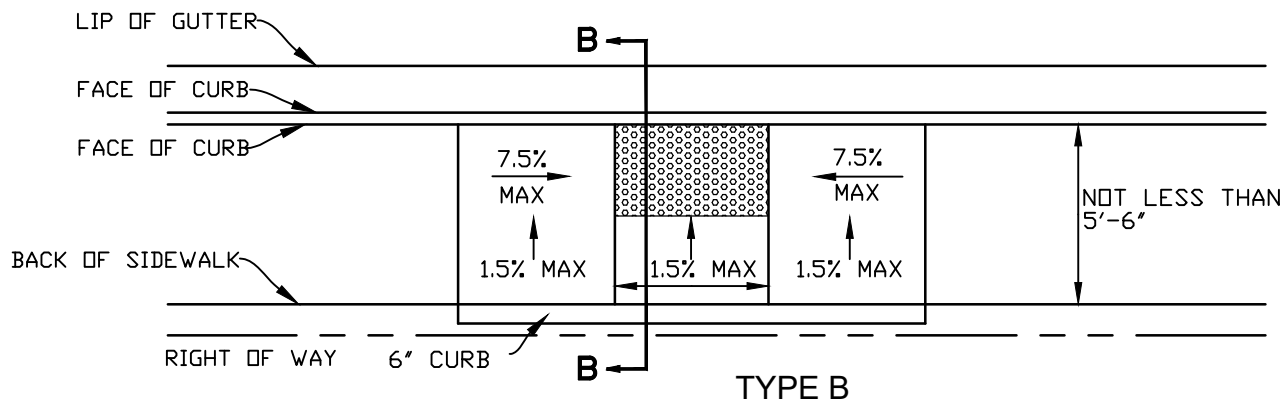

4" CLASS II A.B. 95% R.C.

**SECTION B-B**

**NOTES:**

1. RAMP SHALL BE CONSTRUCTED WITH ½" LIP AND 45° BEVEL.
2. TYPE A AND C RAMPS SHALL BE LOCATED AT THE CENTER OF THE CURB RETURN.
3. CONCRETE SHALL BE CLASS "A" WITH NOT LESS THAN 6 SACKS OF CEMENT PER CUBIC YARD.
4. DESIGN SHALL CONFORM TO THESE REQUIREMENTS, EXCEPT AS OTHERWISE APPROVED BY THE CITY ENGINEER.
5. NEW CONCRETE POURED ADJACENT TO EXISTING CONCRETE SHALL CONTAIN AT LEAST ONE POUND OF LAMPBLACK PER CUBIC YARD.



**PEDESTRIAN RAMP TYPE B AND C**

STD. NO.

**R-3.2**

SCALE: NONE | DRAWN: LMM | APPROVED: JG, CITY ENGINEER

DATE: JUNE 2021

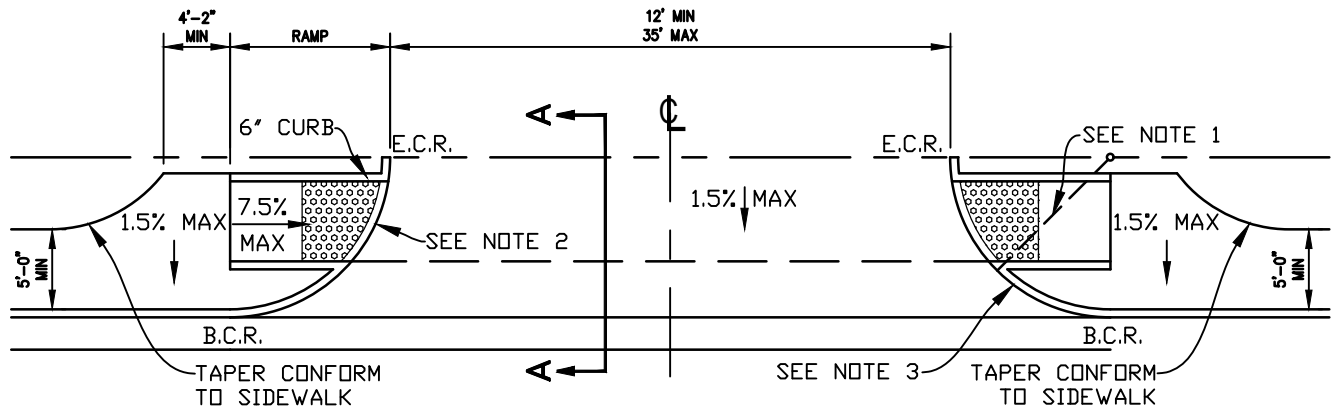

**COMMERCIAL DRIVEWAY**

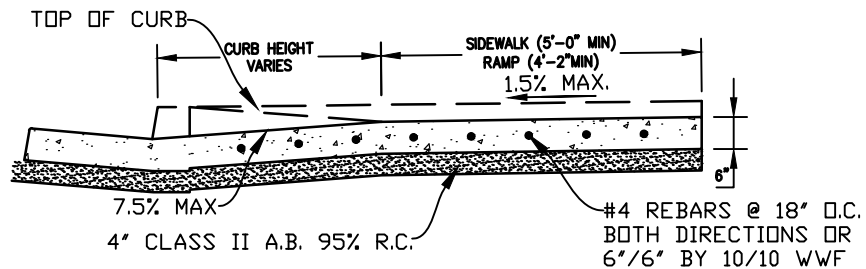

**SECTION A-A**

**NOTES:**

1. RADIUS TO BE A MINIMUM OF 10 FEET.
2. RAMP SHALL BE FLUSH ACROSS DRIVEWAY.
3. CURB HEIGHT VARIES FROM FULL HEIGHT AT B.C. TO FLUSH AT RAMP.
4. NEW CONCRETE POURED ADJACENT TO EXISTING CONCRETE SHALL CONTAIN AT LEAST ONE POUND OF LUMPBLACK PER CUBIC YARD.



**COMMERCIAL DRIVEWAY  
AND ALLEY APPROACH**

STD. NO.  
**R-4.1**

SCALE: NONE | DRAWN: LMM | APPROVED: JG, CITY ENGINEER

DATE: JUNE 2021

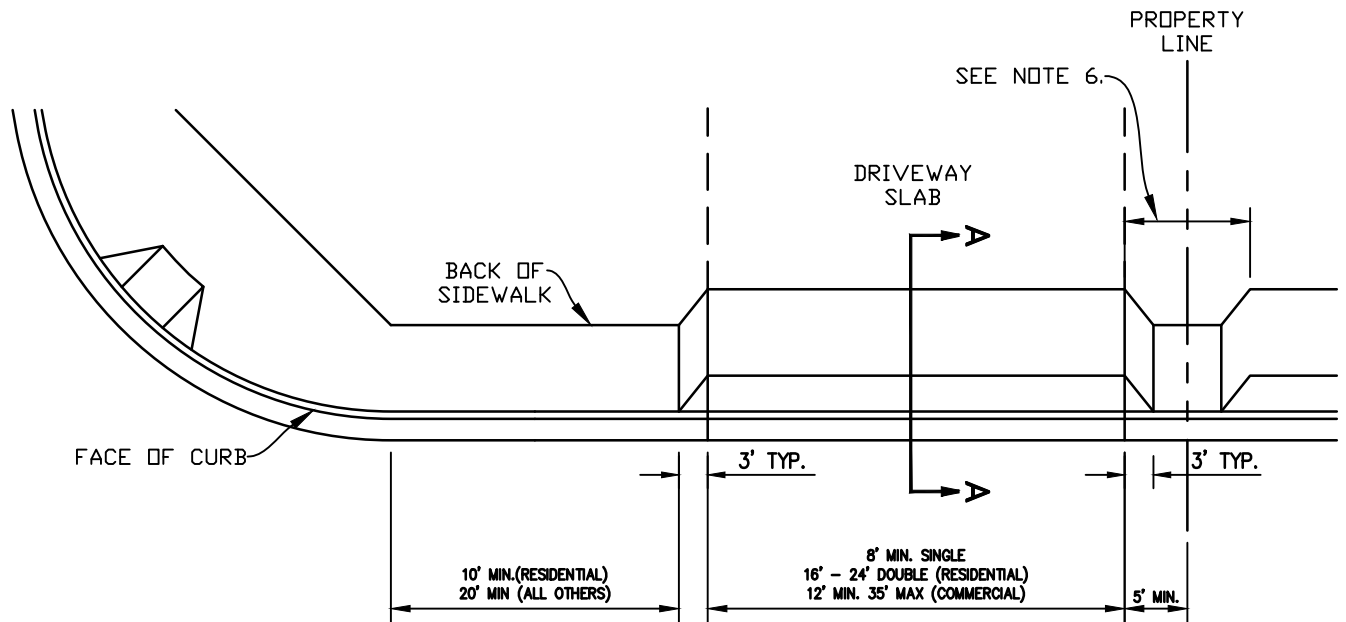

PLAN

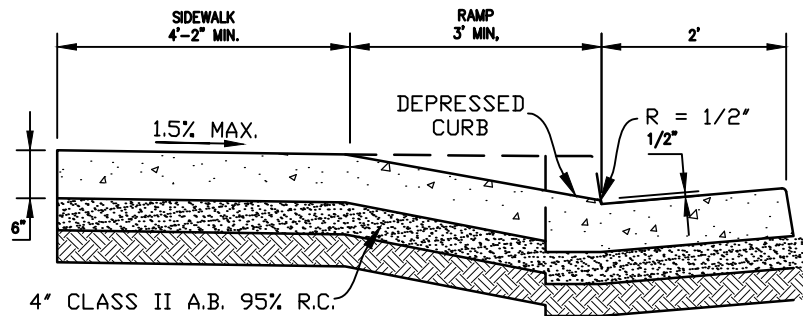

SECTION A-A

NOTES:

1. WEAKENED PLANE JOINTS SHALL BE INSTALLED AT THE CENTER OF ALL DRIVEWAYS OVER 20' WIDE.
2. MAXIMUM SIDEWALK CROSS SLOPE 1.5%.
3. WIDEN OR MEANDER SIDEWALK AT OBSTRUCTIONS (INCLUDING DRIVEWAYS) TO MAINTAIN A 4'-2" MINIMUM CLEARANCE.
4. ALL CONCRETE SHALL BE CLASS "A" CONTAINING NOT LESS THAN 6 SACKS OF CEMENT PER CUBIC YARD.
5. WELDED WIRE FABRIC (4"X4",10/10) SHALL BE PLACED THROUGHOUT COMMERCIAL AND INDUSTRIAL DRIVEWAYS WITHIN THE STREET RIGHT OF WAY.
6. IF DISTANCE BETWEEN DRIVEWAYS IS LESS THAN 10', OMIT CURB ISLAND.
7. NEW CONCRETE POURED ADJACENT TO EXISTING CONCRETE SHALL CONTAIN AT LEAST ONE POUND OF LAMPBLACK PER CUBIC YARD.



**DRIVEWAY**

STD. NO.

**R-4.2**

SCALE: NONE

DRAWN: LMM

APPROVED:

JG, CITY ENGINEER

DATE: JUNE 2021

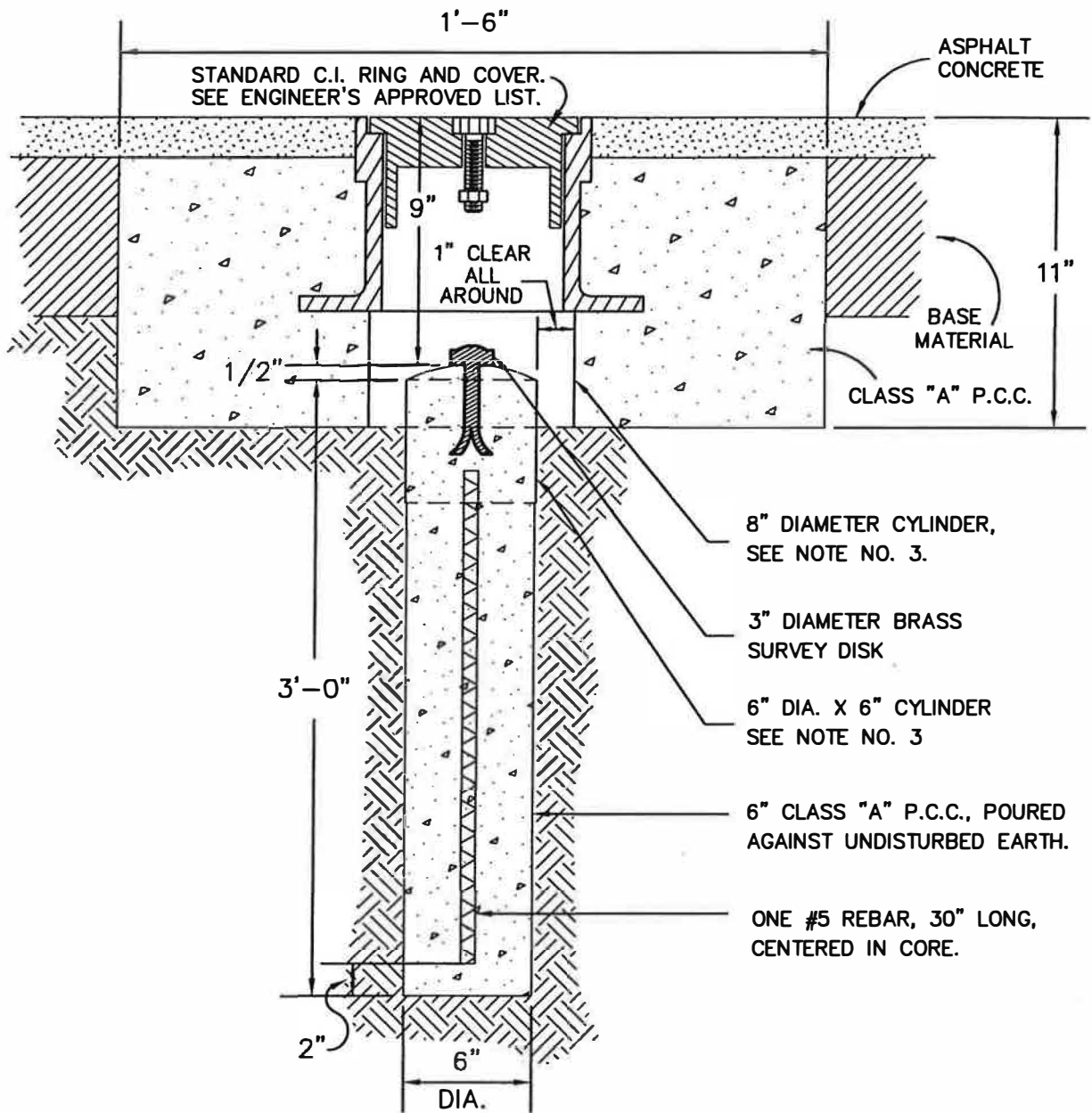

**NOTES:**

1. SURVEYOR OR ENGINEER SETTING THE MONUMENT SHALL INDICATE EXACT POINT BY MAKING A CROSS ON THE CAP AND SHALL STAMP YEAR SET AND HIS/HER LICENSE TYPE AND NUMBER.
2. THE DEPTH OF THE MONUMENT POST SHALL BE LENGTHENED OR SHORTENED AS DICTATED BY THE GROUND CONDITIONS OR AS APPROVED BY THE CITY ENGINEER. IN SOFT GROUND OR FILL AREAS THE MONUMENT POST SHALL BE LENGTHENED TO BED IT ON A STABLE BASE.
3. CYLINDER MATERIAL SHALL BE THINWALL A.B.S. OR P.V.C. PLASTIC PIPE.
4. TOP OF MONUMENT CORE SHALL BE FINISHED SMOOTH AND ROUNDED WITH NO CONCRETE ABOVE EDGE OF BRASS SURVEY MARKER.
5. ASTM CLASS 30 IRON CASTINGS DIPPED IN ASPHALT PAINT



**CITY MONUMENT**

STD. NO.  
**R-5.1**

SCALE: NONE | DRAWN: MGA | APPROVED: JG, CITY ENG. | DATE: JUNE 2021

# SIDEWALK WARP

\* MAY BE REDUCED TO 3" ON EXISTING STREETS TO PROVIDE A MINIMUM SIDEWALK CLEARANCE OF 3 FEET.

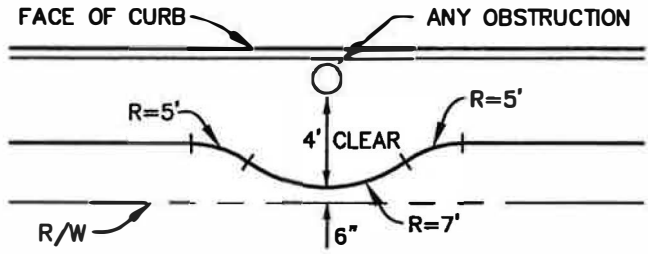

CENTER SIDEWALK WARPS ABOUT LOT LINES

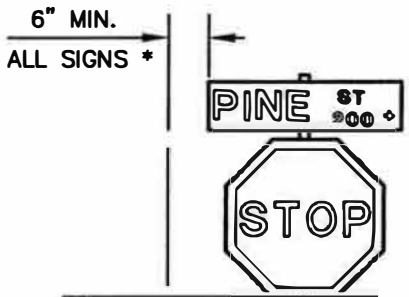

STANDARD 30" STOP SIGN (36" AT STATE HIGHWAY)

7' MIN.  
ALL SIGNS

SIGN POST TO BE 2" STANDARD GALVANIZED PIPE

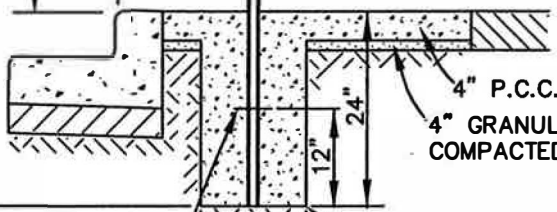
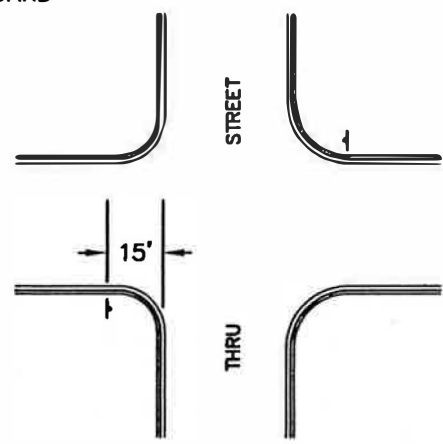

4" P.C.C.  
4" GRANULAR MATERIAL COMPACTED TO 95%

6" x 3/8" REBAR OR BOLT

BASE OF SIGN TO BE POURED WITH CLASS "A" P.C.C.



## STREET NAME SIGN AND SIDEWALK WARP

STD. NO.  
**R-5.2**

SCALE: NONE | DRAWN: LMM | APPROVED: JG, CITY ENG. | DATE: JUNE 2021

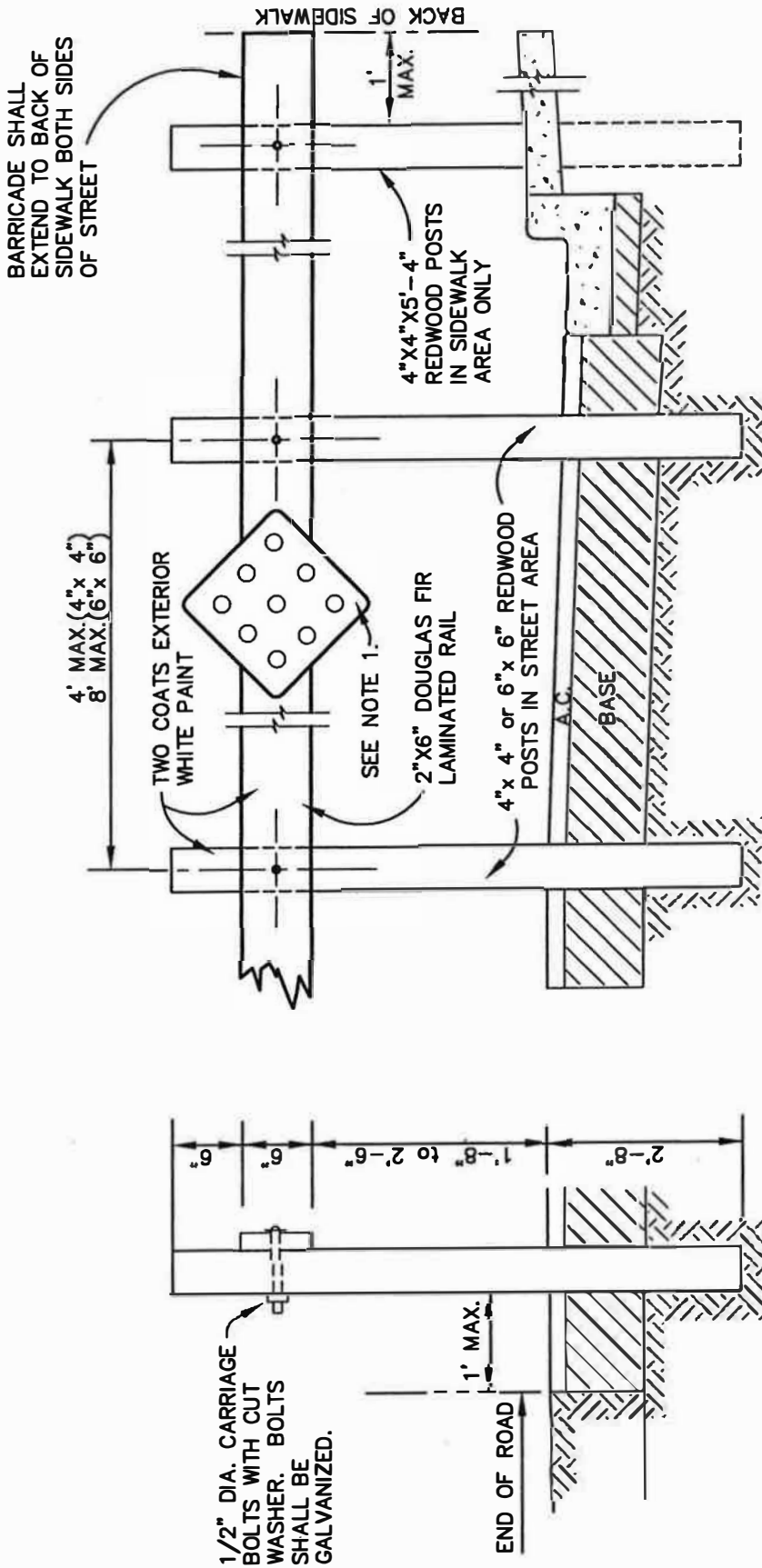

**NOTES:**

1. INSTALL 18" X 18" ALUMINUM TYPE N-5 REFLECTOR, NO MORE THAN 8' o.c., MINIMUM 3
2. SIDEWALKS ONLY - INSTALL 4" YELLOW REFLECTORS.



**STANDARD BARRICADE**

**STD. NO.  
R-5.3**

SCALE: NONE

DRAWN: MGA

APPROVED:

JG, CITY ENG.

DATE: JUNE 2021

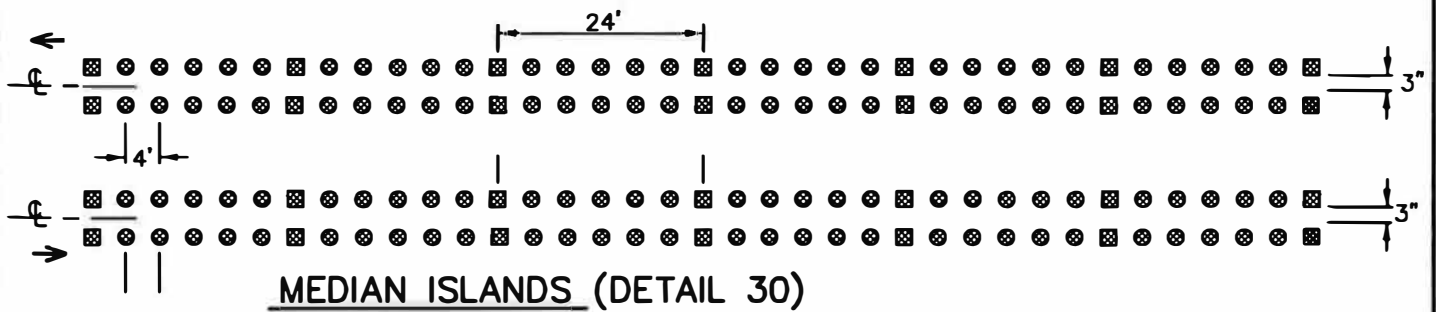
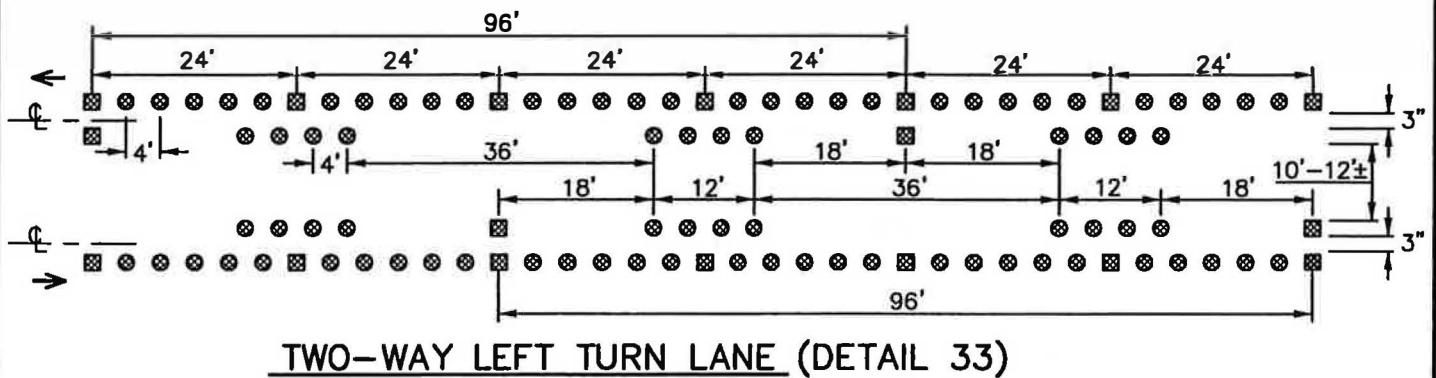
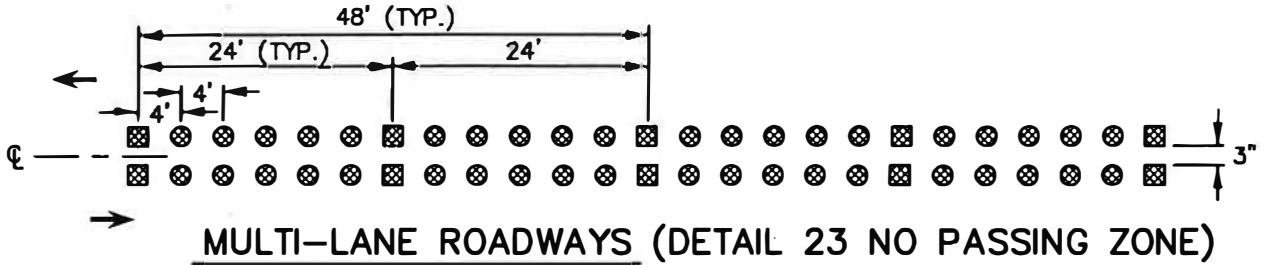
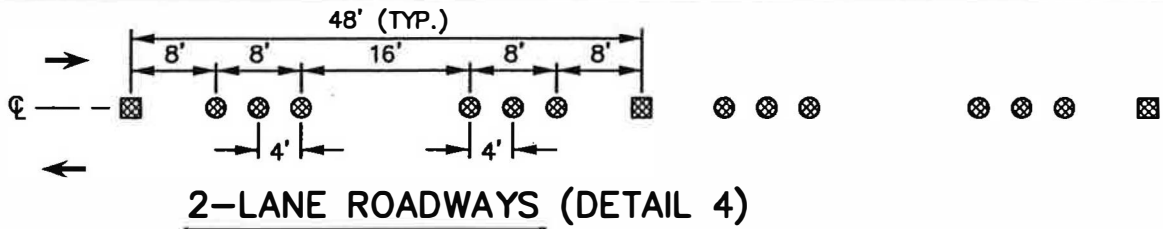

**LEGEND**

- TWO-WAY YELLOW REFLECTIVE MARKER
- NON-REFLECTIVE YELLOW MARKER
- ➔ DIRECTION OF TRAVEL

**NOTES:**

1. FOR TWO LANE ROADWAYS, PLACE ADDITIONAL REFLECTORS AT 24 FT. O.C. ON CURVES WITH A RADIUS OF 750 FT. OR LESS.
2. THE FIRST AND LAST MARKER AT EACH INTERSECTION SHALL BE A REFLECTOR.
3. DESIGN SHALL CONFORM TO THESE REQUIREMENTS EXCEPT AS OTHERWISE APPROVED BY THE CITY ENGINEER
4. ALL PARKERS AND MARKER INSTALLATION SHALL MEET STATE STANDARDS EXCEPT AS NOTED.



**PAVEMENT MARKINGS: CENTER LINES,  
TWO-WAY LEFT TURN LANES,  
AND MEDIAN ISLANDS**

**STD. NO.  
R-5.4**

SCALE: NONE

MGA

APPROVED:

JG, CITY ENG.

DATE: JUNE 2021

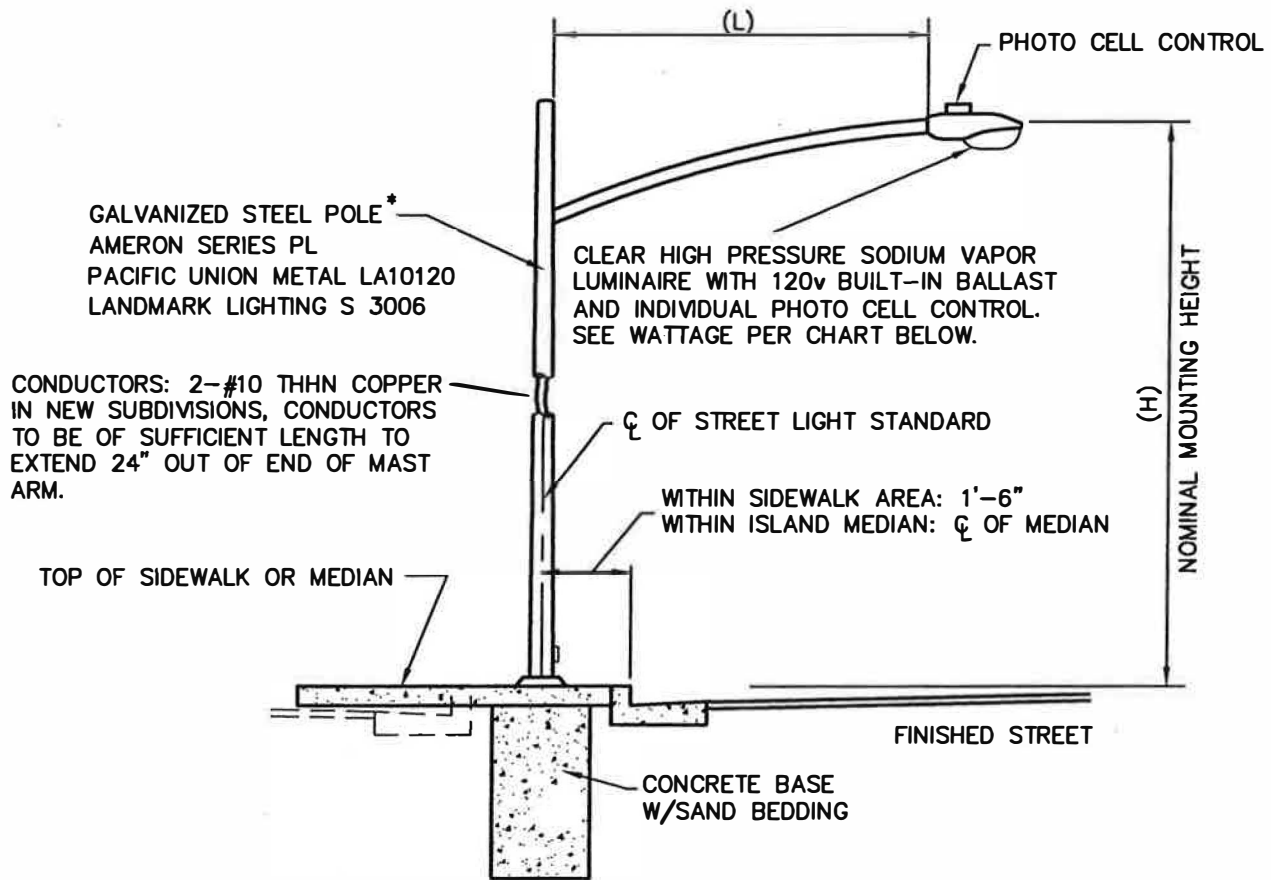

CONDUCTORS: 2-#10 THHN COPPER IN NEW SUBDIVISIONS, CONDUCTORS TO BE OF SUFFICIENT LENGTH TO EXTEND 24" OUT OF END OF MAST ARM.

TOP OF SIDEWALK OR MEDIAN

WITHIN SIDEWALK AREA: 1'-6"  
WITHIN ISLAND MEDIAN: CL OF MEDIAN

INSTALL #5 CONCRETE PULLBOX @ ALL LIGHT STANDARDS, NEXT TO POLE, PARALLEL AND FLUSH TO CURB & GUTTER

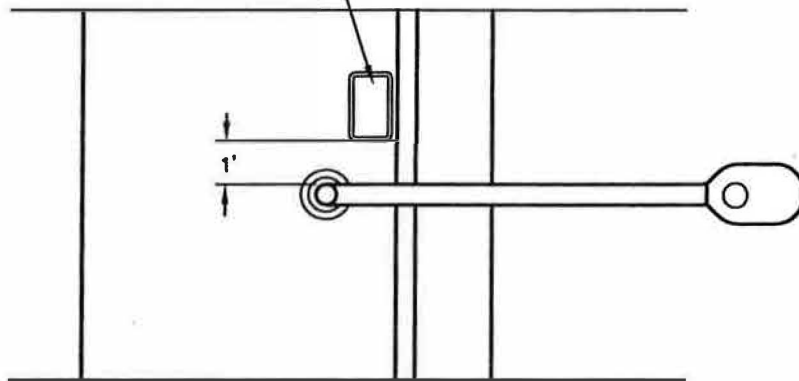

\*ALTERNATES TO BE SPECIFICALLY APPROVED BY THE CITY ENGINEER.

STREET CLASSIFICATION	POLE HEIGHT(H)	ARM LENGTH(L)	MAXIMUM SPACING	WATTAGE
ARTERIAL	32'-6"	8'-0"	100'	150
COLLECTOR, CUL-DE-SAC	28'-0"	6'-0"	200'	100
LOCAL	27'-6"	4'-0"	200'	70



## STREET LIGHT

STD. NO.  
**R-6.1**

SCALE: NONE

DRAWN: LMM

APPROVED:

JG, CITY ENG.

DATE: JUNE 2021



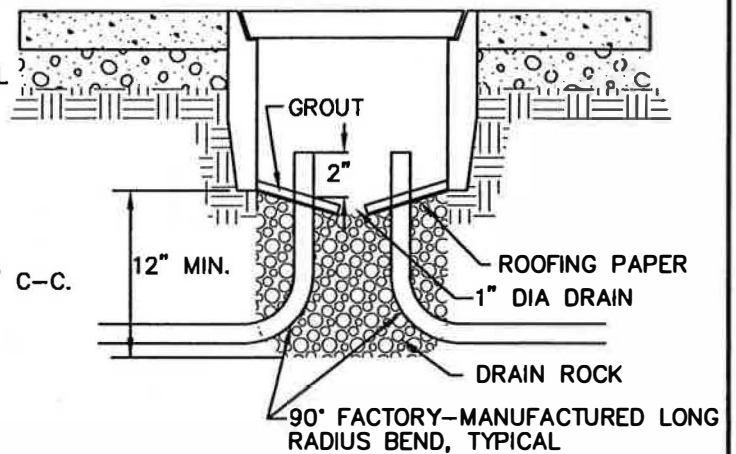
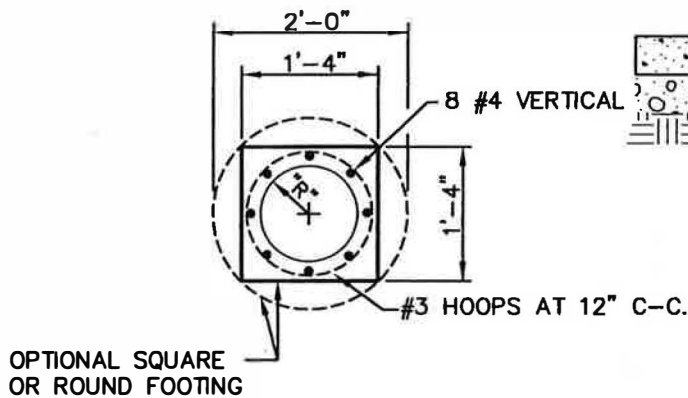
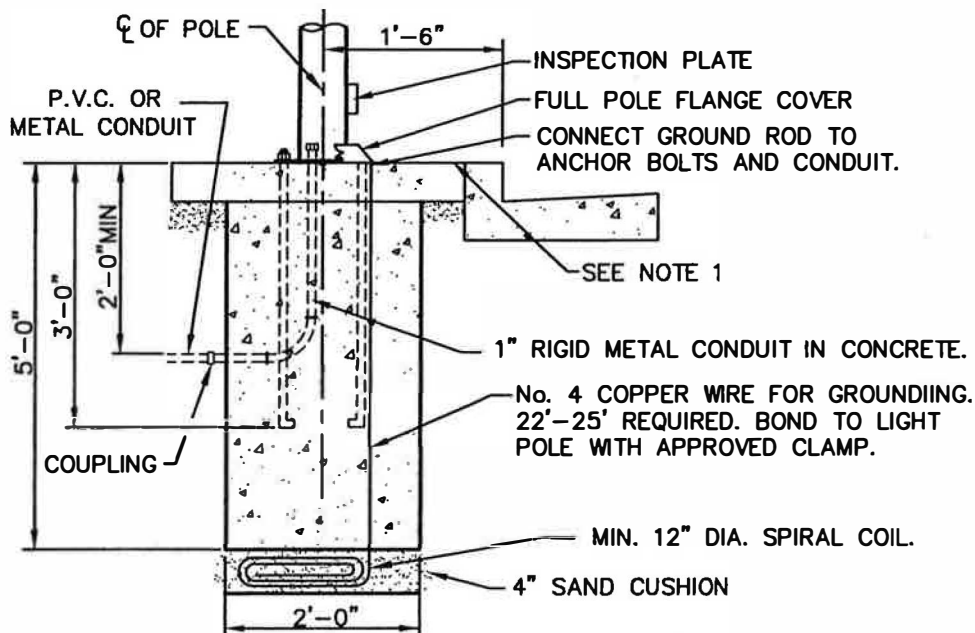

PULLBOX

**NOTES:**

- 1 IN UNDEVELOPED AREAS, CONSTRUCT A 2'x2' CONC. PAD (4" THICK). IF ROUND FOOTING IS POURED, STOP AT THE ELEVATION OF BOTTOM OF THE SIDEWALK.
- 2 ANCHOR BOLT DIMENSION "R" AND BOLT PATTERN TO SUIT POLE BASE FURNISHED.
- 3 CONCRETE SHALL BE CLASS "A" P.C.C. AGAINST UNDISTURBED SOIL.
- 4 SEE ENGINEER'S APPROVED LIST FOR ALTERNATE FOUNDATIONS.
- 5 A MINIMUM OF TWO FULL THREADS TO BE EXPOSED ABOVE ANCHOR BOLT NUTS.



**STREET LIGHT POLE FOUNDATION**

**STD. NO.  
R-6.2**

SCALE: NONE    DRAWN: LMM    APPROVED: JG, CITY ENG.    DATE: JUNE 2021